

SPECIFICATION

A: MATERIAL:

- 1.BODY: NYLON 66
- 2.TERMINAL: Cu PLATED Sn

B: CHARACTERISTICS:

- 1.RATING: 15A 250V~(C-ULus)
10A 250V~(ENEC & CCC & KC)
- 2.INSULATION RESISTANCE:100MΩ MIN,AT 500VDC
- 3.ELECTRIC STRENGTH : 3000 VAC/1MIN,LEAKAGE CURRENT UNDER 0.5mA

C: APPROVALS:C-ULus, ENEC & CCC & KC

D: MATERIAL USED MUST BE COMPLY WITH HQI-0010

E: CAN MEET RoHS,RoHS2.0,HF

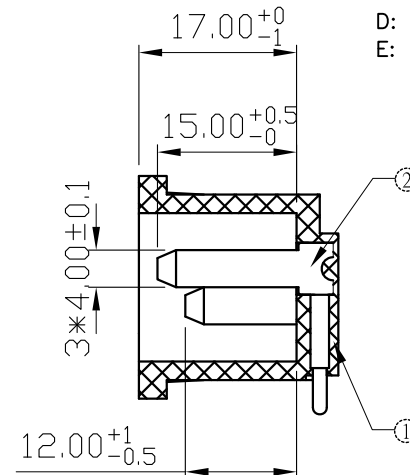
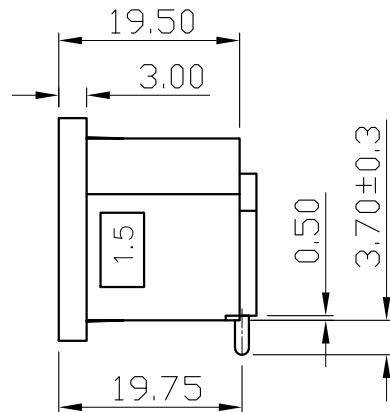
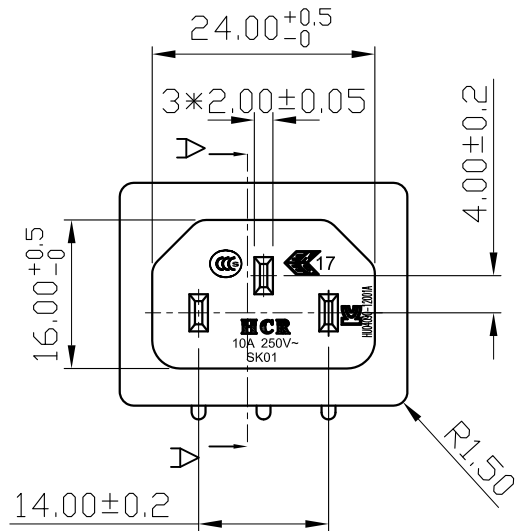

SECTION A-A

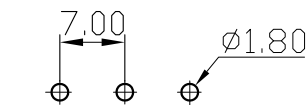
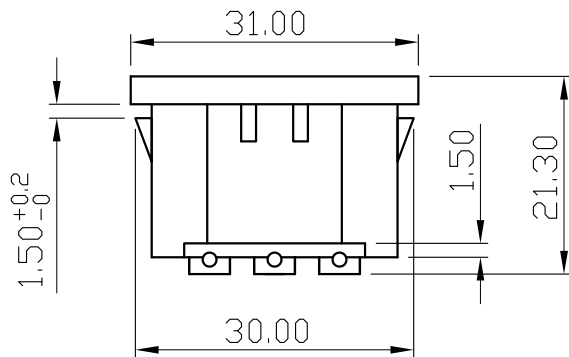
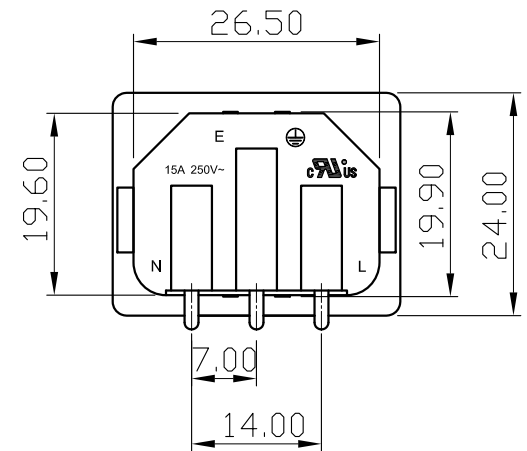

PCB LAYOUT

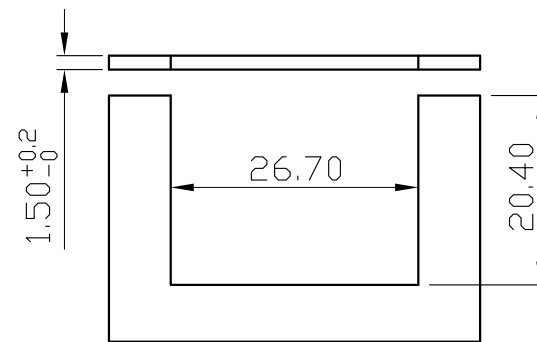

PANEL CUT-OUT

TOLERANCES UNLESS OTHERWISE 未指定容許差尺寸之公差	
BASIC DIMENSIONS TOLERANCES	
UP TO 10 (10以下)	±0.15
ABOVE 10 TO 30(10~30)	±0.3
ABOVE 30 TO 100(30~100)	±0.5
ANGULAR DIMENSIONS(角度)	±5°
DIMENSION UNIT	mm

東莞市華之力電子有限公司 DONGGUAN HCR ELECTRONICS CO., LTD.

NO	DATE	REVISION DESCRIPTION	REVISION	DRAWN	APPROVED	繪圖 DRAWN BY	日期 DATE	20121122	路徑 DWG NO	E:\成品圖 SK01\800117	料號 ITEM NO	SK01-3101092321H
2						核准 APPROVED BY	日期 DATE	20121122	投影法 PROJECT		機型 PART NAME	INLET SOCKET
1						校對 CHECKED BY	日期 DATE	20121122	比例 SCALE	1:1	型號 PART NO	SK01
0	20121122	1.新制訂	A0			繪圖 DRAWN BY	日期 DATE	20121122	路徑 DWG NO	E:\成品圖 SK01\800117	料號 ITEM NO	SK01-3101092321H